

NOTES: UNLESS OTHERWISE SPECIFIED

1. SEE DRAWING NO. CB-00294 AND PROCEDURE P-1000 FOR ASSEMBLY AND TEST INSTRUCTION. PROCEDURES AND ASSEMBLY DRAWINGS ARE FOR INTERNAL USE ONLY.
2. ALL TESTING ARE IAW BATTERY COUNCIL INTERNATIONAL STANDARDS.
3. ALL DIMENSIONS ARE IN INCHES [MM].

REVISIONS			
REV	DESCRIPTION	DATE	APPROVED

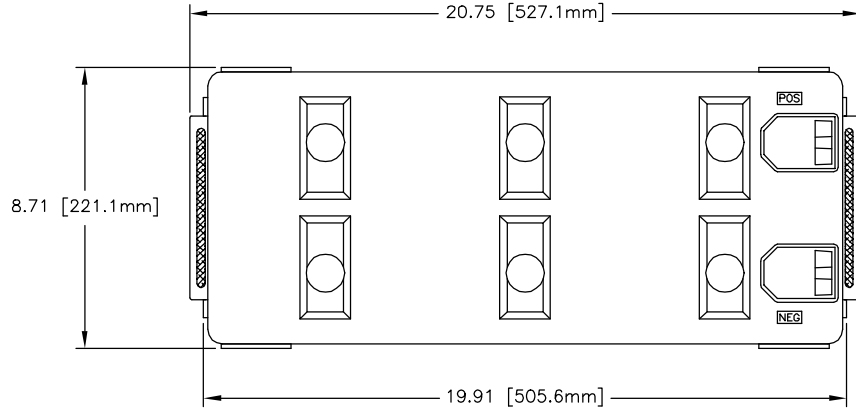

AGM-12210 TERMINAL OPTIONS

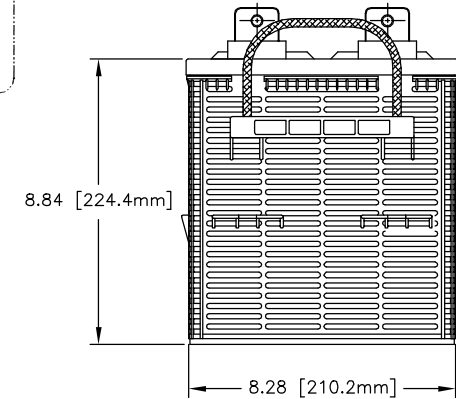
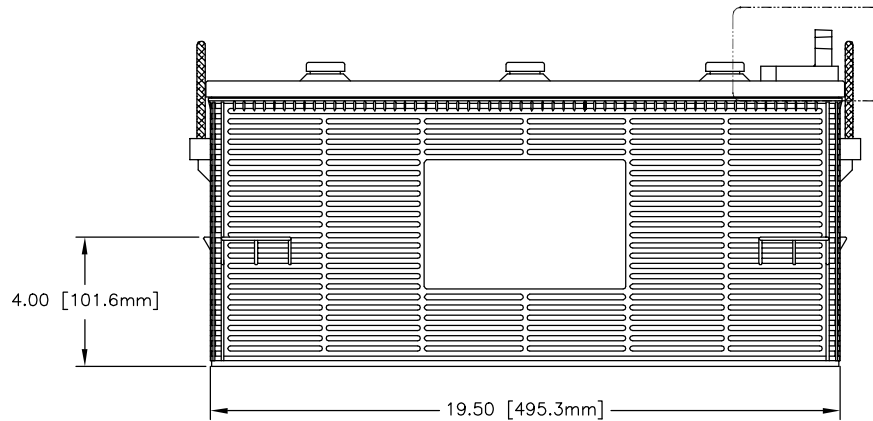
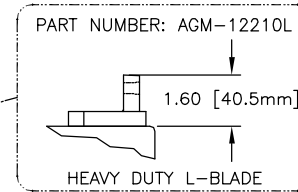

CAPACITY RATINGS	
PART NUMBER	AGM-12210
NOMINAL WEIGHT	135 LBS[61.2 KG]
AMPERE HOUR CAPACITY @ 20 HOUR 1.75 VOLTS/CELL @ 77°F (25° C)	210 AH
MINUTES OF DISCHARGE @ 25 AMPS 1.75 VOLTS/CELL @ 77°F (25° C)	390 MIN

ENVELOPE DRAWING

QTY REQD	CAGE CODE	PART OR IDENTIFYING NO.	NOMENCLATURE OR DESCRIPTION	MATERIAL SPECIFICATION	ITEM NO.
PARTS LIST					
UNLESS OTHERWISE SPECIFIED DIMENSIONS ARE IN INCHES TOLERANCES ARE: FRACTIONS DECIMALS ANGLES .XX ± .06 .XXX ± .060			CONTRACT NO.	CONCORDE BATTERY CORPORATION 2009 SAN BERNARDINO RD, W. COVINA, CA 91790	
APPROVALS		DATE	TITLE		
DRAWN	ELH	3/21/00	BATTERY, 12 VOLT, AGM-12210		
TREATMENT	NONE	CHECKED	S. VALDEZ	3/21/00	SIZE
FINISH	NONE	APPROVED	DG	3/22/00	CAGE CODE
SIMILAR TO	N/A	ACT WT	N/A	CALC WT	N/A
ISSUED	DR	3/22/00	SCALE	NONE	DWG NO.
					AGM-12210
				SHEET	1 OF 1