

NOTES: UNLESS OTHERWISE SPECIFIED

1. SEE DRAWING NO. CB-00278 AND PROCEDURE P-1000 FOR ASSEMBLY AND TEST INSTRUCTION. PROCEDURES AND ASSEMBLY DRAWINGS ARE FOR INTERNAL USE ONLY.
2. ALL TESTING ARE IAW BATTERY COUNCIL INTERNATIONAL STANDARDS.
3. ALL DIMENSIONS ARE IN INCHES [MM].
4. ABBREVIATION USED IN TITLE IS: ABSORBED GLASS MAT (AGM)

REVISIONS			
REV	DESCRIPTION	DATE	APPROVED
A	REVISED CAPACITY TABLE	3/15/00	JBT
B	REMOVED AGM-1285T	3/17/00	MK
C	METRICIZED INSERT AND REV. ASSY NO. WAS: CB-00280	12/23/00	JBT
D	ADDED AGM-1285T RATES, & NOTE 4	11/15/02	JBT

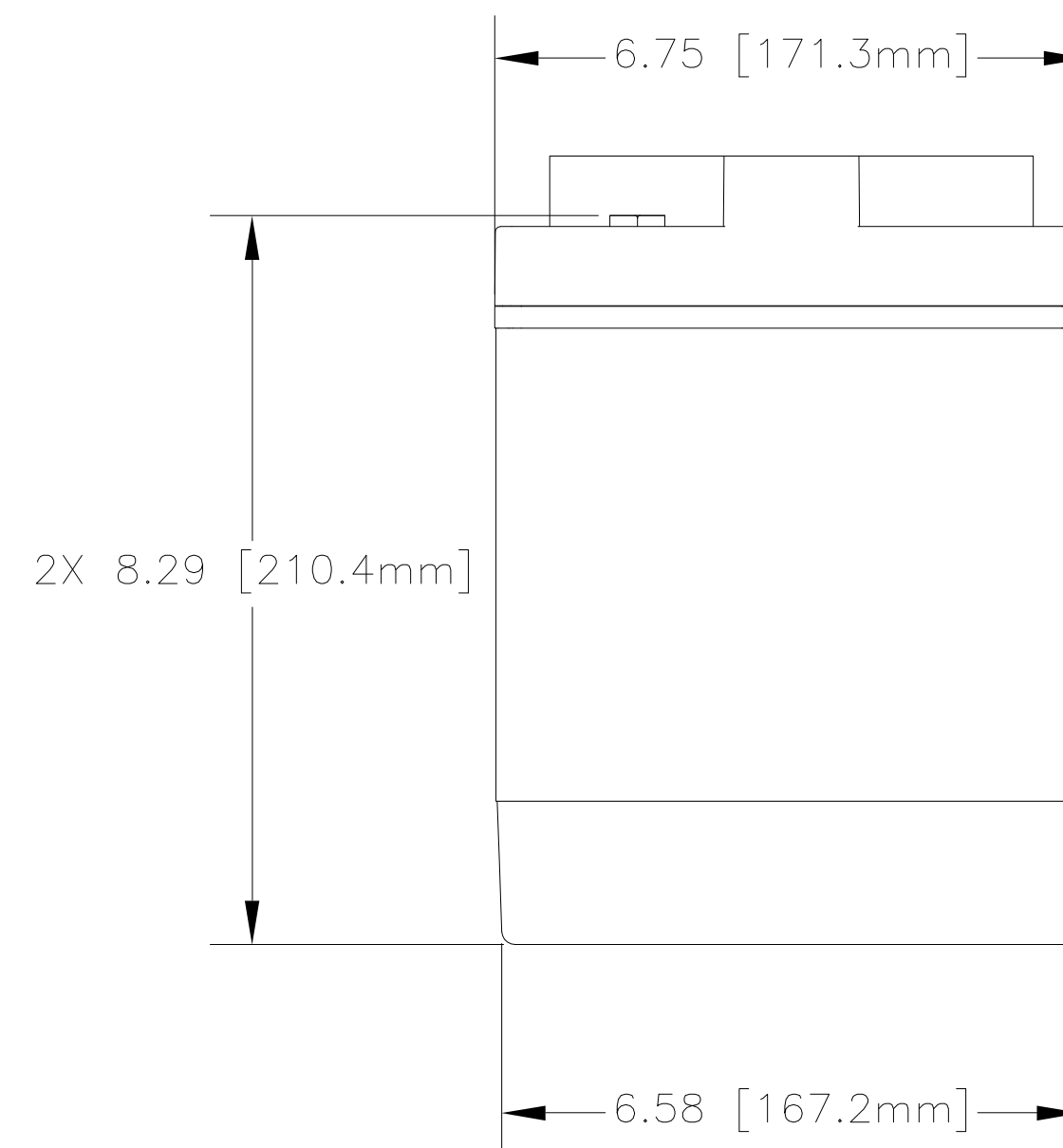
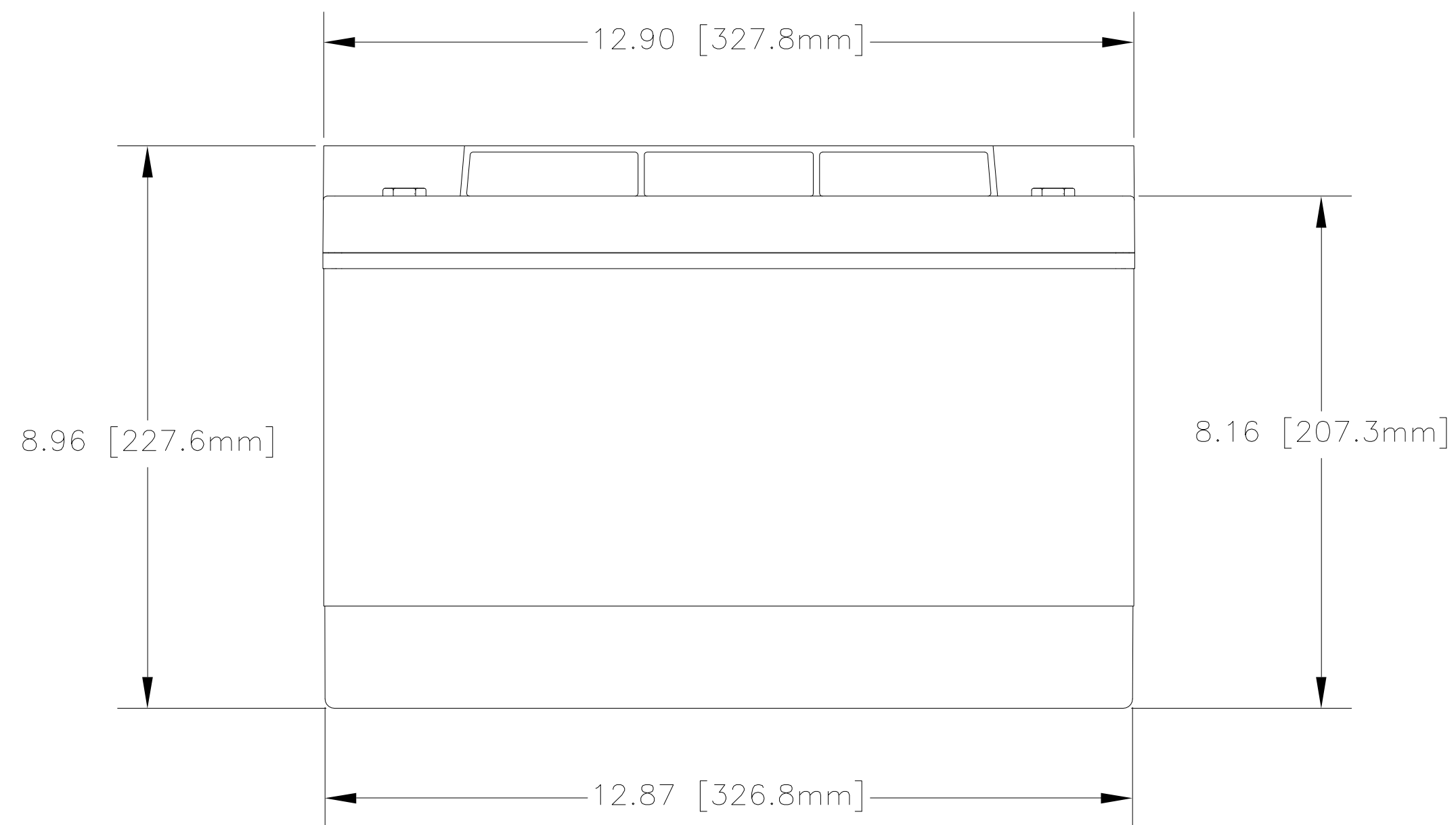
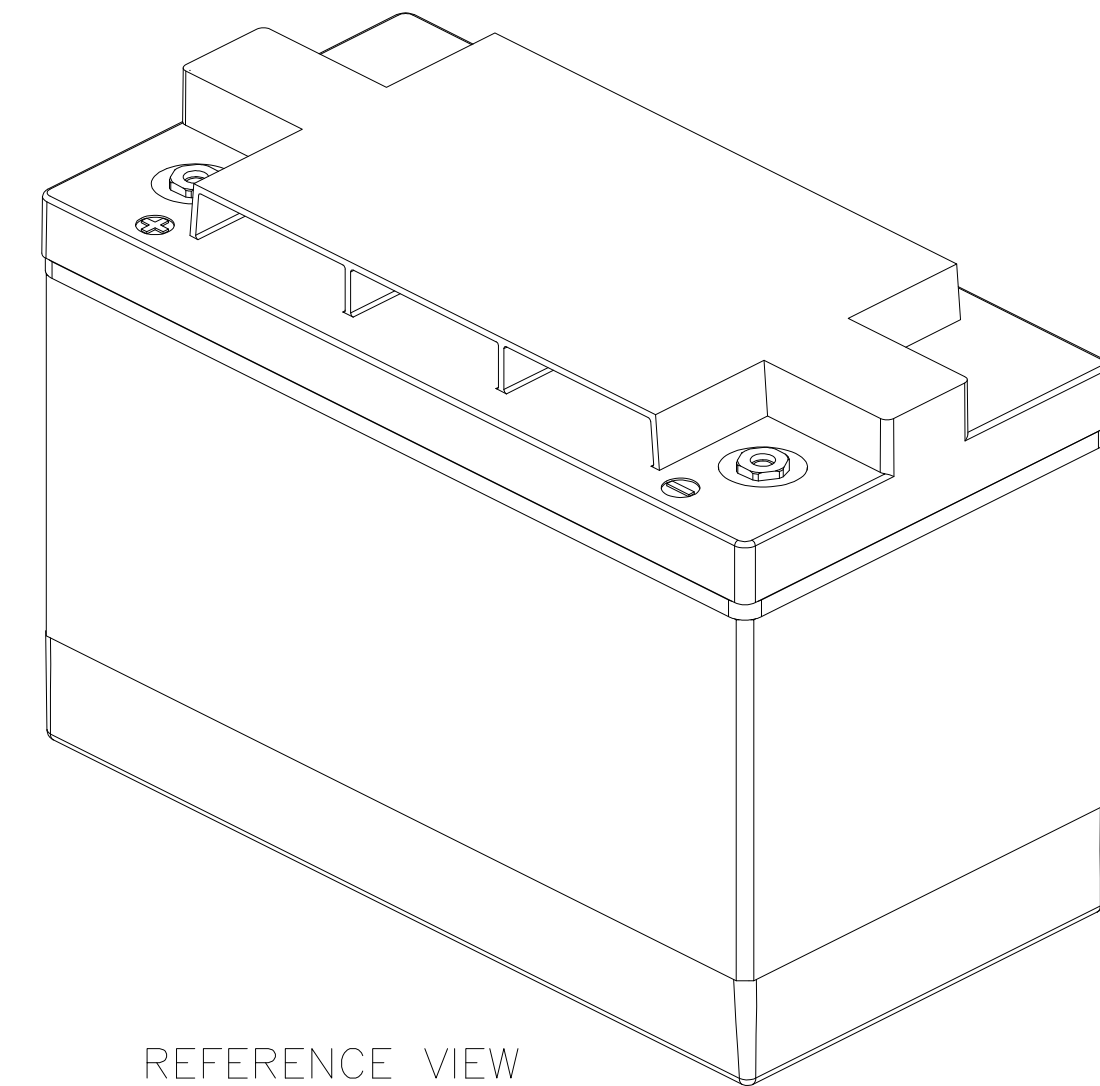
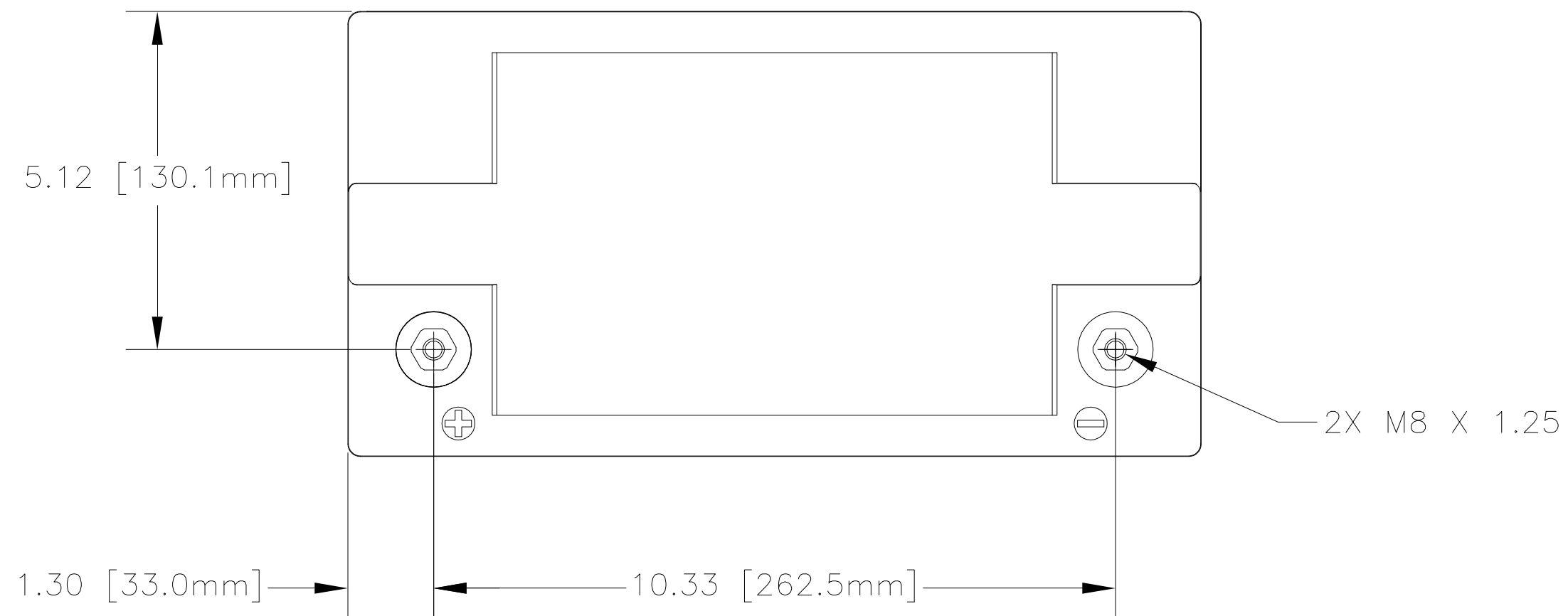

CAPACITY RATINGS

PART NUMBER	AGM-1285T	AGM-12105T
NOMINAL WEIGHT	62 LBS [28.2 KG]	69 LBS [31.3 KG]
AMPERE HOUR CAPACITY @ 20 HOUR 1.75 VOLTS/CELL @ 77°F (25°C)	85 AH	105 AH
MINUTES OF DICHARGE @ 25 AMPS 1.75 VOLTS/CELL @ 77°F (25°C)	158 MIN	195 MIN

ENVELOPE DRAWING

QTY REQD	CAGE CODE	PART OR IDENTIFYING NO.	NOMENCLATURE OR DESCRIPTION	MATERIAL SPECIFICATION	ITEM NO.
PARTS LIST					
UNLESS OTHERWISE SPECIFIED DIMENSIONS ARE IN INCHES TOLERANCES ARE: FRACTIONS DECIMALS ANGLES ± 1/32 .XX ± .06 ± 1° .XXX ± .060			CONCORDE BATTERY CORPORATION 2009 SAN BERNARDINO RD, W. COVINA, CA 91790		
TREATMENT NONE		APPROVALS		DATE	
FINISH NONE		DRAWN ELH		3/1/00	
SIMILAR TO NA		CHECKED S.VALDEZ		3/1/00	
ACT WT NA		APPROVED JBT		3/4/00	
CALC WT NA		ISSUED AT		11/21/02	
TITLE			BATTERY, 12 VOLT, AGM-12105T SERIES		
SIZE	CAGE CODE	DWG NO.	REV		
C	63017	AGM-12105T	D		
SCALE NONE			SHEET 1 OF 1		

ENGINEERING COPY 21NOV02