

NOTES: UNLESS OTHERWISE SPECIFIED

1. SEE DRAWING NO. CB-00297 AND PROCEDURE P-1000 FOR ASSEMBLY AND TEST INSTRUCTION. PROCEDURES AND ASSEMBLY DRAWINGS ARE FOR INTERNAL USE ONLY.
2. ALL TESTING ARE IAW BATTERY COUNCIL INTERNATIONAL STANDARDS.
3. ALL DIMENSIONS ARE IN INCHES [MM].

REVISIONS			
REV	DESCRIPTION	DATE	APPROVED
A	REVISED TERMINAL POST	7/23/01	JBT

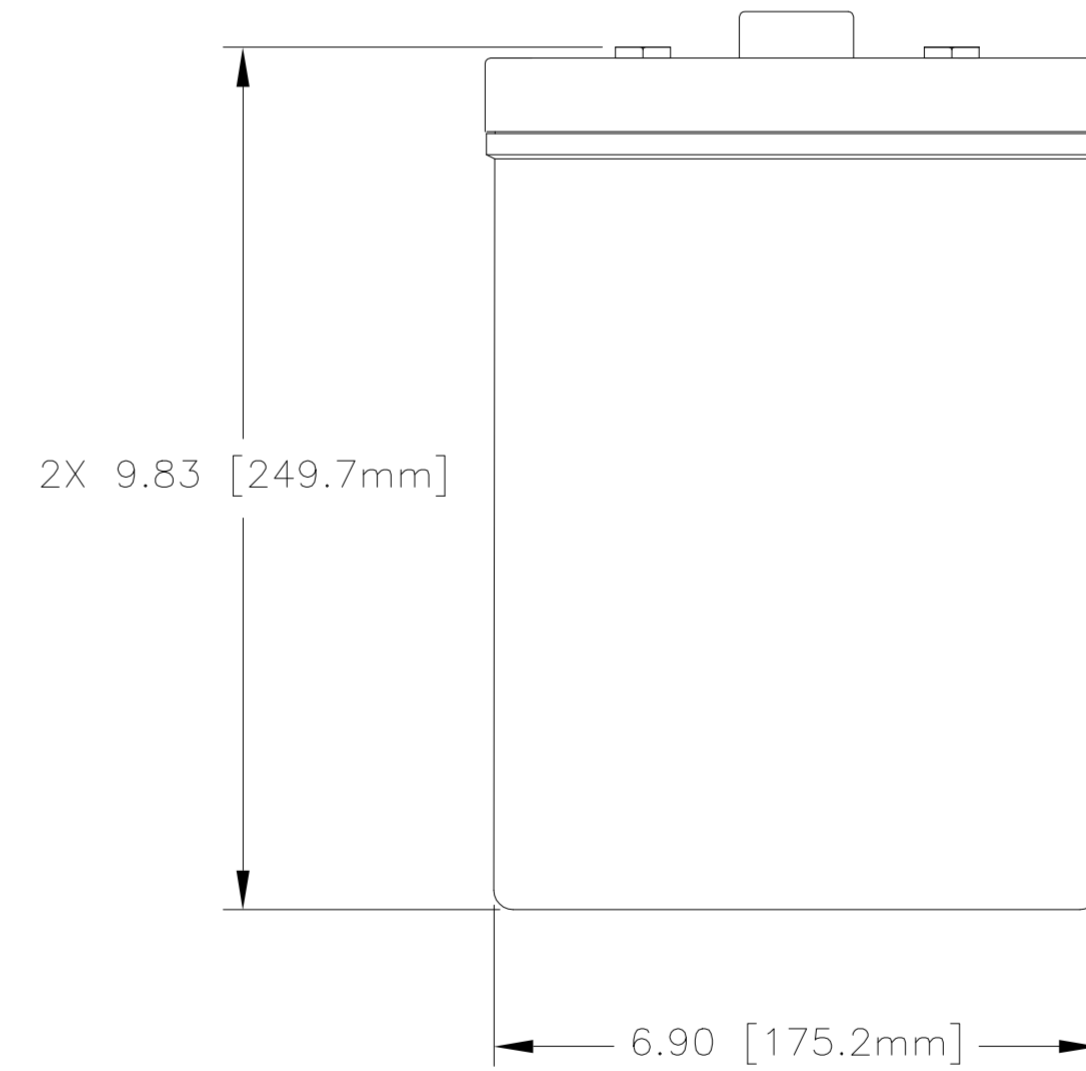
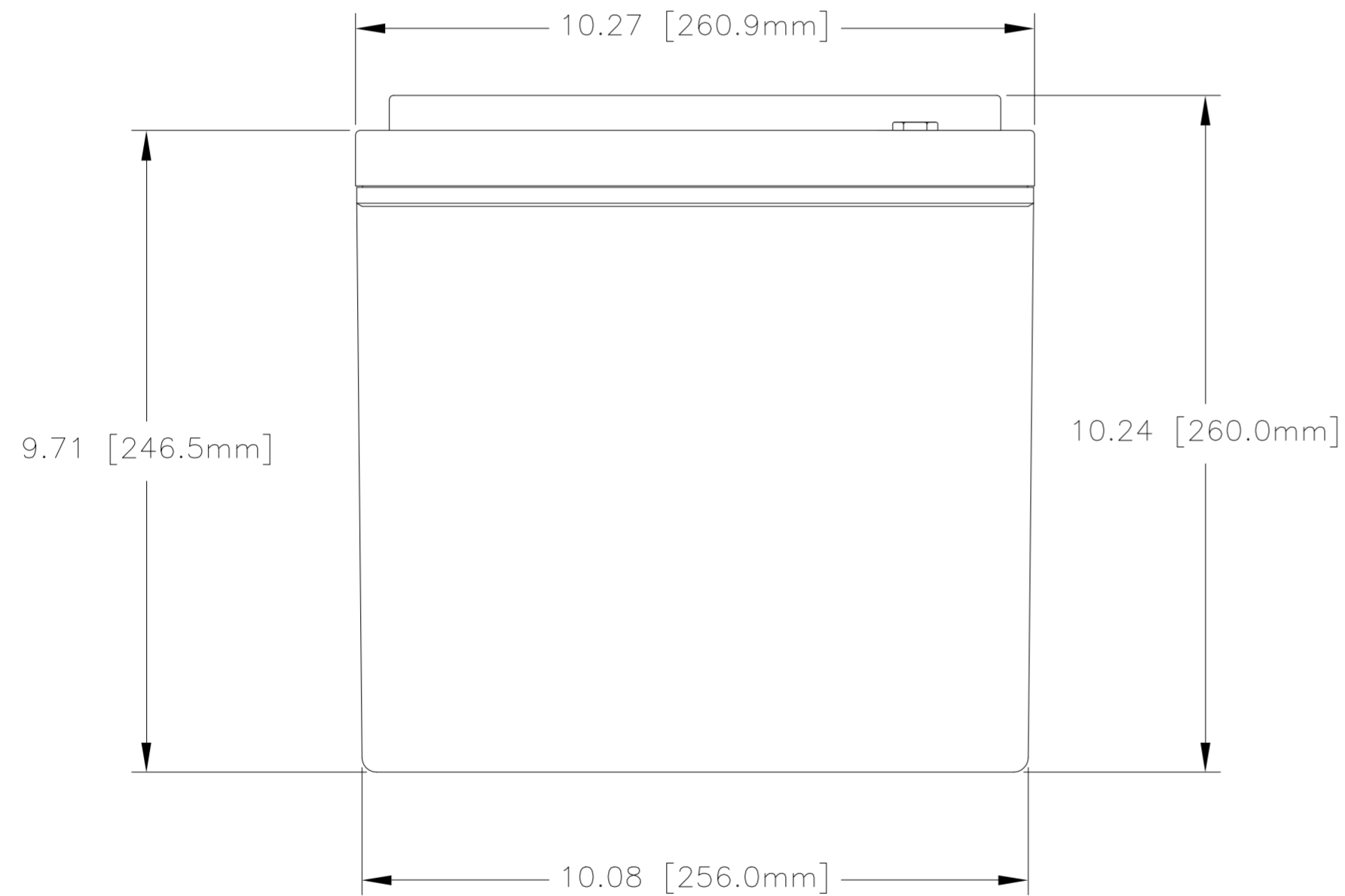
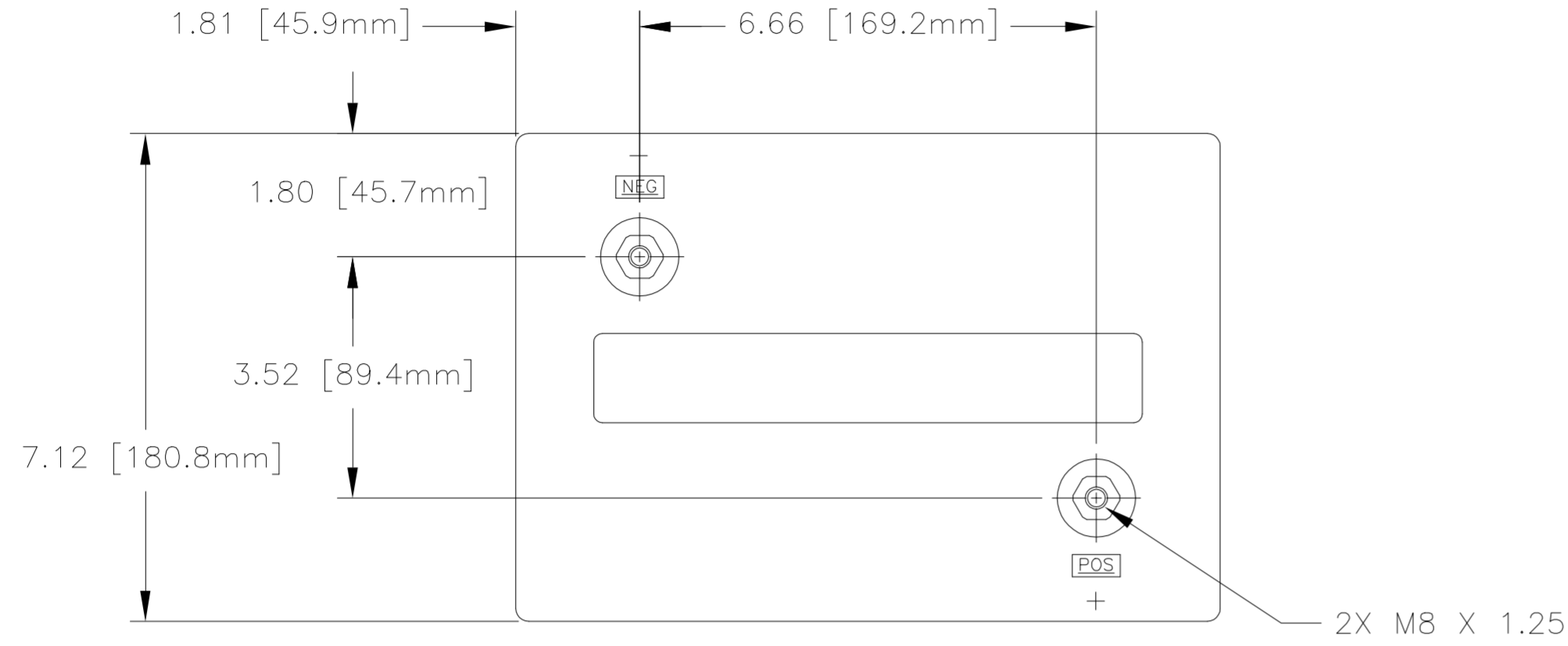

CAPACITY RATINGS	
PART NUMBER	AGM-6220
NOMINAL WEIGHT	66 LBS [30.0 KG]
AMPERE HOUR CAPACITY @ 20 HOUR 1.75 VOLTS/CELL @ 77°F (25° C)	220 AH
MINUTES OF DISCHARGE @ 25 AMPS 1.75 VOLTS/CELL @ 77°F (25° C)	492 MIN

ENVELOPE DRAWING

QTY REQD	CAGE CODE	PART OR IDENTIFYING NO.	NOMENCLATURE OR DESCRIPTION	MATERIAL SPECIFICATION	ITEM NO.
PARTS LIST					
UNLESS OTHERWISE SPECIFIED DIMENSIONS ARE IN INCHES TOLERANCES ARE: FRACTIONS DECIMALS ANGLES .XX ± .06 .XXX ± .030			CONTRACT NO.		CONCORDE BATTERY CORPORATION 2009 SAN BERNARDINO RD, W. COVINA, CA 91790
TREATMENT NONE			APPROVALS	DATE	
FINISH NONE			DRAWN ELH	3/21/00	TITLE BATTERY, 6 VOLT, AGM-6220
SIMILAR TO N/A			CHECKED S. VALDEZ	3/21/00	SIZE C
ACT WT N/A			APPROVED DG	3/22/00	CAGE CODE 63017
CALC WT N/A			ISSUED AT	8/6/01	DWG NO. AGM-6220
			SCALE NONE		REV A
			SHEET 1 OF 1		

ENGINEERING COPY 06AUG01